

# ROOF CURB ASSEMBLY INSTRUCTIONS EMS#1007743

LENNOX LGA 156-240

CURB ASSEMBLY NUMBER

1007743

Drawn By: CJT  
Drawn Date: 02/01/07

REV:

**ESTIMATED WEIGHT: 190 LBS.**

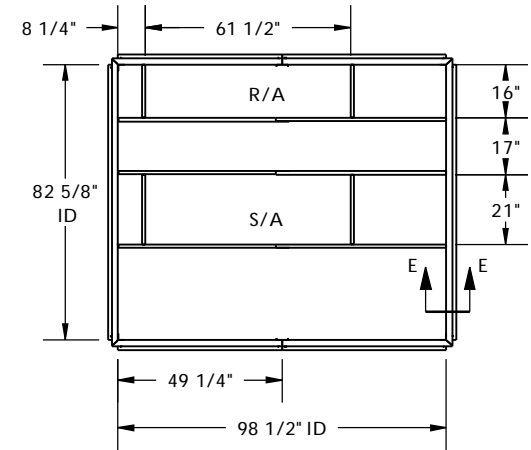
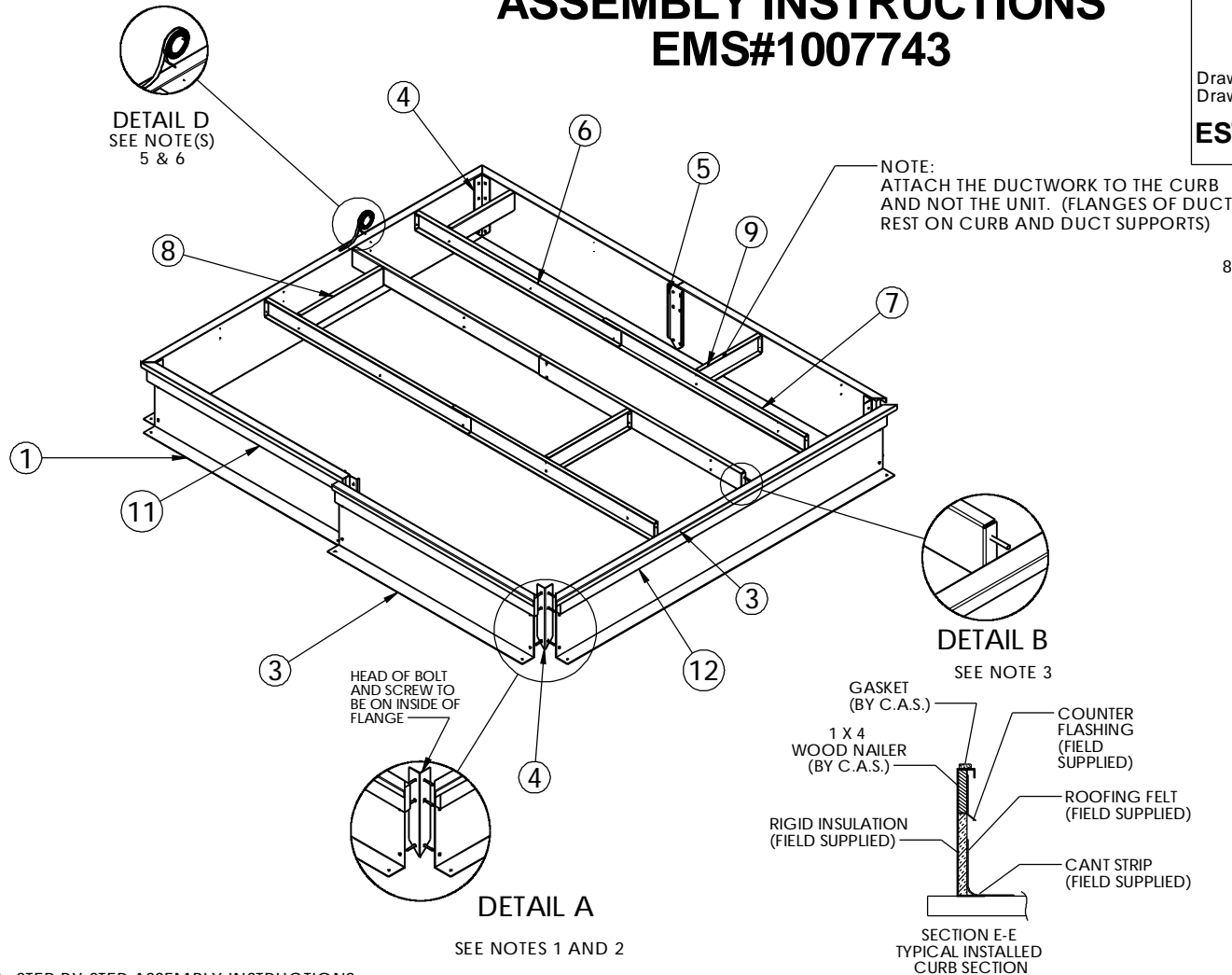

13	Bag, Hardware, #1 CP	2
12	WOOD 1X4 X 82 1/2"	2
11	WOOD 1X4 X 50 5/16"	4
10	GASKET 1-1/4X 1/4 X 25'	3
9	SUPPORT, DUCT	2
8	SUPPORT, DUCT	2
7	TELE-SUPPORT, OUTER	3
6	TELE-SUPPORT, INNER	3
5	BUTT STRAP 1	2
4	CORNER CLIP 1	4
3	SIDE-3	2
2	SIDE-2	2
1	SIDE-1	2
ITEM NO.	DESCRIPTION	QTY.

## NOTES: STEP-BY-STEP ASSEMBLY INSTRUCTIONS

1. ARRANGE SIDES AND ENDS TOGETHER AT RIGHT ANGLES AS SHOWN. SEE DETAIL A.
2. BOLT SIDES AND ENDS TOGETHER AS SHOWN USING THE 4 CORNER BRACKETS, BOLTS, AND THE TEK SCREWS PROVIDED. SEE DETAIL A.
3. PUT 10-16 X 3/4" TEK SCREWS IN PROVIDED PILOT HOLES IN SIDES AND ENDS AS NECESSARY. INSERT SLOTTED ENDS OF DUCT SUPPORTS OVER SCREWS AND TIGHTEN IF NECESSARY. REPEAT AT ALL DUCT SUPPORT LOCATIONS. SEE DETAIL B.
4. WHEN NEEDED PLACE THE INSULATED PANELS TOGETHER WITH FORMED FLANGES FACING DOWN ALLOWING FLANGED PORTION OF PANELS TO REST ON SIDE RAILS. (GASKET WILL HOLD PANELS IN PLACE.) SEE DETAIL C.
5. REMOVE PAPER BACKING FROM THE PROVIDED GASKETING AND APPLY TO TOP PERIMETER OF ROOF CURB AND DUCT SUPPORTS. (SEE ILLUSTRATION ABOVE). SET CURB IN PLACE OVER ROOF OPENING. LEVEL CURB AND SECURE TO ROOF. SEE DETAIL D.
6. **IMPORTANT: THE GASKETING OF THE UNIT TO THE ROOF CURB IS CRITICAL FOR WATER TIGHTNESS. INSTALL GASKET SUPPLIED WITH ROOF CURB AS SHOWN IN DETAIL D, & NOTE 5. IMPROPERLY APPLIED GASKET CAN RESULT IN AIR LEAKS AND POOR UNIT PERFORMANCE.**

**Cambridgeport**  
AIR SYSTEMS, INC.

SALISBURY, MA 01952

PHONE 1-800-648-2872 FAX 1978-462-9189