

ADJUSTABLE ROOF CURB SUBMITTAL #MA15764

CARRIER 48/50 PG 20,24

ADJ. CURB ASSEMBLY, 36A NUMBER

1010450

REV:

Drawn By: JBH
Drawn Date: 6-20-08

ESTIMATED WEIGHT: 316 LBS.

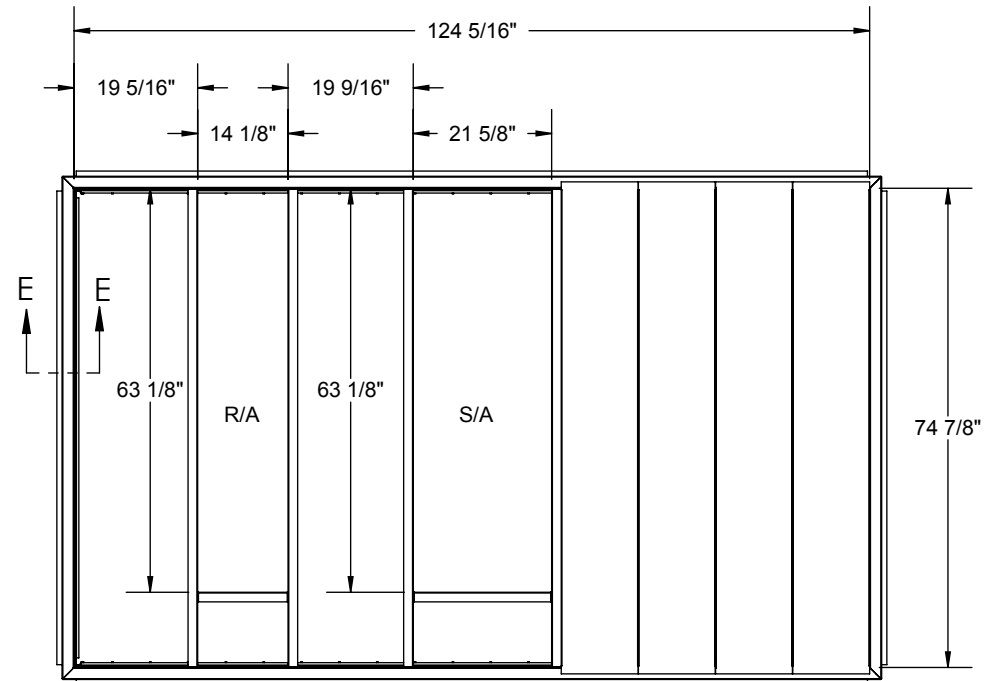
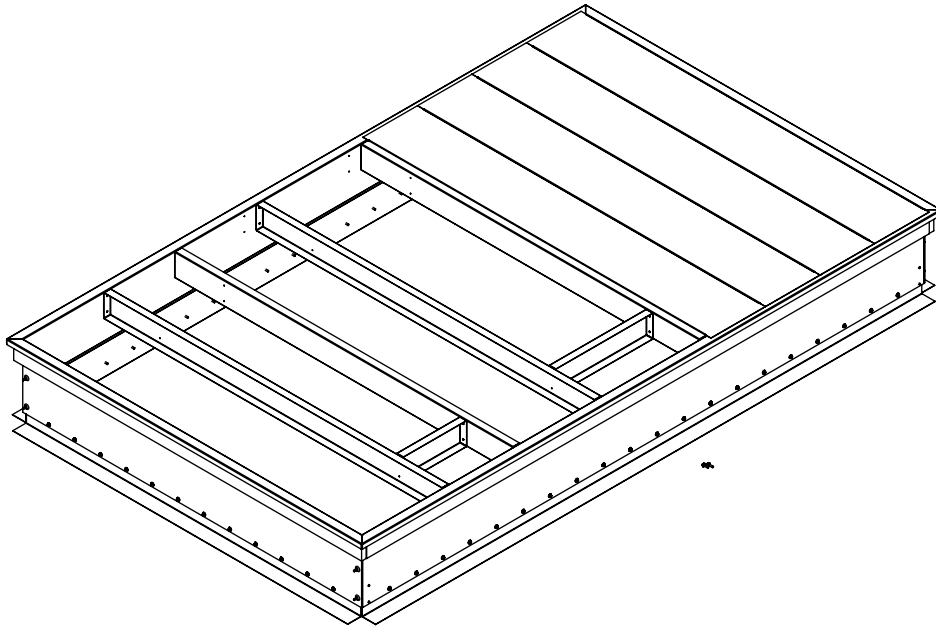

FEATURES:

FULLY ADJUSTABLE HEIGHT AND PITCH
UP TO 1" PER FOOT IN ANY DIRECTION

MITERED TOP CORNERS

ROOF CURB BODY IS FABRICATED OF HEAVY
GAUGE GALVANIZED STEEL

FULL PERIMETER WOOD NAILER

PRE-PUNCHED ASSEMBLY HOLES AND HARDWARE
INCLUDED FOR DUCT SUPPORT INSTALLATION

ROOF CURB IS SHIPPED KNOCKED DOWN

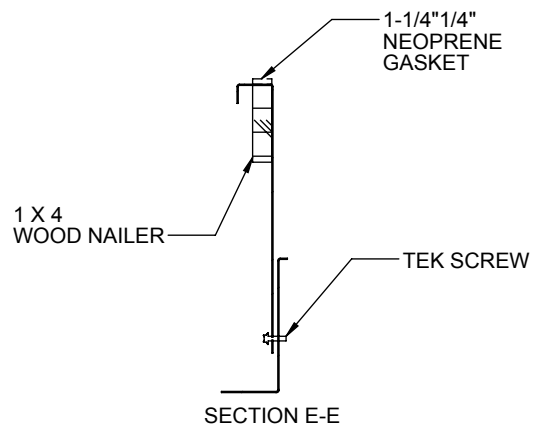

© 2007 COX ENGINEERING COMPANY
DBA CAMBRIDGEPORT AIR SYSTEMS. ALL RIGHTS RESERVED

Cambridgeport
AIR SYSTEMS, INC.

SALISBURY, MA 01952

PHONE 1-800-648-2872 FAX 1978-462-9189